

CUSTOMER
 CUSTOMER SIGNATURE FOR APPROVAL
 DATE

| | |
|---------------------|-------|
| SPLINE PROFILE | P1 |
| DIN5482 - A | 40x36 |
| module - M | 1.9 |
| teeth - Z | 20 |
| Dp. | 38 |
| MEASURING OVER PINS | |
| 32.75 - 33 | |
| Ø PIN | Ø 3.5 |

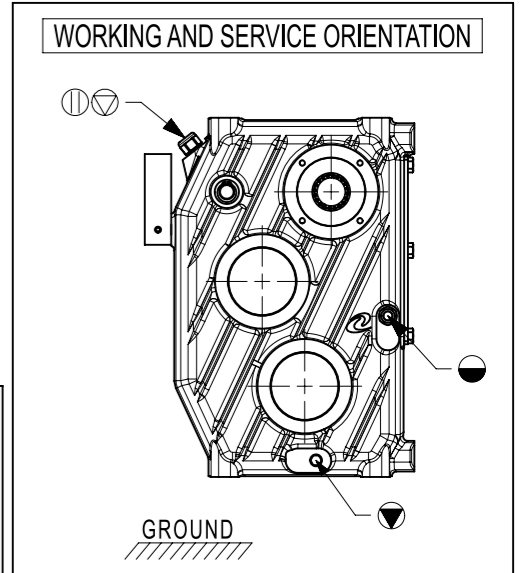

NOTE:

- DIMENSIONS WITHOUT TOLERANCE ARE FOR REFERENCE ONLY
- FOR DIMENSIONS NOT SPECIFIED REFER TO THE 3D MODEL

SHIFTING INSTRUCTIONS:

- THE GEAR SHIFTING MUST BE DONE WHEN THE PTO SHAFT IS COMPLETELY STOPPED.
- AFTER SHIFTING, SET THE ENGINE SPEED AT MINIMUM SPEED/RPM AND THEN ENGAGE THE PTO SHAFT.

| | | | | | |
|------------------------------|------------|--------------------|--------------------------|----------------|------------------------|
| Target life 2000 hrs | | | Duty cycle - performance | | |
| Continuous power performance | | | Ratio | | |
| Ratio | Power (Hp) | Output torque (Nm) | Ratio | Power "A" (Hp) | Output torque "A" (Nm) |
| R 1.8:1 | 100 | 2340 | R 1.8:1 | 120 | 2810 |
| R 1:1 | 115 | 1495 | R 1:1 | 145 | 1885 |

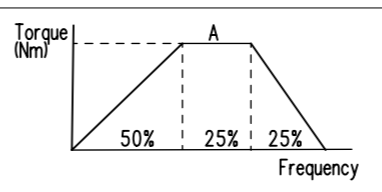

Rapporto Ratio Verhältniss Rapport
 1 : 1 1.8 : 1

Lubricant
 Oil Litres Grease kg.
 Recommended type SAE 90 EP
 Estimated quantity 8.7
 Gearbox supplied with Lubricant Yes No

| | |
|---|--|
| Giri in entrata g/min. Input speed r.p.m. Eingangsdrehzahl u/min. Tours en entrée tr/min. | 540 |
| Potenza in entrata Input power Eingangsleistung Puissance en entrée | See table HP kW |
| Coppia in uscita Output torque moment Ausgangsdrehmoment Couple en sortie | See table da Nm |
| Peso - Weight - Gewicht - Poids | 95 kg. |
| Cuscinetti Bearings Lager Roulements | A 30210 B 32210 C D E F G H |
| Denti diritti Straight Gerade Droite | <input checked="" type="checkbox"/> |
| Denti elicoidali Helicoidal Schraubenfoermig Helicoidale | <input type="checkbox"/> |

Tappo sfiato - Breather plug Entlüftungsstopfen-Bouchon ventilation

Tappo carico - filler plug Fullstopfen - Bouchon remplissage

Tappo livello - Level plug Standschraube - Bouchon niveau

Tappo scarico - Drain plug Ablassraube - Bouchon vidange

In.

1 : X 1 : 1 X : 1

| | | | |
|---|--------------|--|-------------|
| Code | 5367.001.118 | Customer Ref. | - |
| Designation | C-3A | Date | 09/Jun/2021 |
| Gearbox not painted <input checked="" type="checkbox"/> | | Gearbox painted <input type="checkbox"/> | |

COMER INDUSTRIES reserves the right to make any change to this product without prior public acknowledgement
 COMER INDUSTRIES S.p.A. 42046 Villanova di Reggiolo (R.E.) Italia Tel. 0522\974111 fax 0522\973249

S.d.M. 00.27774

